

EMC Test Report

Client Name : Acrel Co.,Ltd.

Address : No.253, Yulv Road, Jiading District, Shanghai China

Product Name : Three-Phase Electric Meter

Date : Jun.27, 2022



Shenzhen Anbotek Compliance Laboratory Limited

Contents

1. General Information	5
1.1. Client Information	5
1.2. Description of Device (EUT)	5
1.3. Auxiliary Equipment Used During Test	5
1.4. Description of Test Modes	6
1.5. Test Summary	6
1.6. Test Equipment List	7
1.7. Description of Test Facility	10
1.8. EMS Performance Criteria	10
2. Power Line Conducted Emission Test	11
2.1. Test Standard and Limit	11
2.2. Test Setup	11
2.3. EUT Configuration on Measurement	11
2.4. Operating Condition of EUT	11
2.5. Test Procedure	12
2.6. Test Results	12
3. Radiated Emission Test	15
3.1. Test Standard and Limit	17
3.2. Test Setup	17
3.3. EUT Configuration on Measurement	17
3.4. Operating Condition of EUT	18
3.5. Test Procedure	18
3.6. Test Results	18
4. Harmonic Current Emission Test	21
4.1. Test Standard	21
4.2. Test Setup	21
4.3. Operating Condition of EUT	21
4.4. Test Results	21
5. Voltage Fluctuations & Flicker Test	22
5.1. Test Standard	22
5.2. Test Setup	22
5.3. Operating Condition of EUT	22
5.4. Test Results	22
6. Electrostatic Discharge Immunity Test	23
6.1. Test Standard and Level	23
6.2. Test Setup	23
6.3. EUT Configuration on Measurement	23
6.4. Operating Condition of EUT	23
6.5. Test Procedure	24
6.6. Test Results	24

7. RF Field Strength Susceptibility Test.....	26
7.1. Test Standard and Level.....	26
7.2. Test Setup.....	26
7.3. EUT Configuration on Measurement.....	27
7.4. Operating Condition of EUT.....	27
7.5. Test Procedure.....	27
7.6. Measuring Results.....	27
8. Electrical Fast Transient/Burst Immunity Test.....	29
8.1. Test Standard and Level.....	29
8.2. Test Setup.....	29
8.3. EUT Configuration on Measurement.....	29
8.4. Operating Condition of EUT.....	29
8.5. Test Procedure.....	30
8.6. Test Results.....	30
9. Surge Immunity Test.....	32
9.1. Test Standard and Level.....	32
9.2. Test Setup.....	32
9.3. EUT Configuration on Measurement.....	32
9.4. Operating Condition of EUT.....	32
9.5. Test Procedure.....	33
9.6. Test Results.....	33
10. Injected Currents Susceptibility Test.....	35
10.1. Test Standard and Level.....	35
10.2. Test Setup.....	35
10.3. EUT Configuration.....	35
10.4. Operating Condition of EUT.....	35
10.5. Test Procedure.....	36
10.6. Test Results.....	36
11. Voltage Dips And Interruptions Test.....	38
11.1. Test Standard and Level.....	38
11.2. Test Setup.....	38
11.3. EUT Configuration on Measurement.....	38
11.4. Operating Condition of EUT.....	38
11.5. Test Procedure.....	39
11.6. Test Results.....	39
APPENDIX I -- TEST SETUP PHOTOGRAPH.....	41
APPENDIX II -- EXTERNAL PHOTOGRAPH.....	44
APPENDIX III -- INTERNAL PHOTOGRAPH.....	46

TEST REPORT

Applicant : Acrel Co.,Ltd.

Manufacturer : Jiangsu Acrel Electrical Manufacturing. Co., Ltd.

Product Name : Three-Phase Electric Meter

Model No. : ADL400,DTSD1352,ADL3000,DTSY1352,DTSF1352,ADL3000-E,ADL3000-EY,ADL3000-EF,ADL3000-EK,ADL3000-ET,ADL3000-EH,ADL3000-E2C,A
DL3000-E/CT,DTSD1352-*

Trade Mark : Acrel

Rating(s) : 220-230V, 50Hz/60Hz, 80A

Test Standard(s) : **BS EN 61326-1: 2013;**
BS EN IEC 61000-3-2: 2019
BS EN 61000-3-3: 2013+A1:2019
(IEC 61000-4-2; IEC 61000-4-3; IEC 61000-4-4;
IEC 61000-4-5; IEC 61000-4-6; IEC 61000-4-8; IEC 61000-4-11)

The device described above is tested by Shenzhen Anbotek Compliance Laboratory Limited to determine the maximum emission levels emanating from the device and the severe levels of the device can endure and its performance criterion. The measurement results are contained in this test report and Shenzhen Anbotek Compliance Laboratory Limited is assumed full responsibility for the accuracy and completeness of these measurements. Also, this report shows that the EUT to be technically compliant with the BS EN61326-1, BS EN IEC 61000-3-2, BS EN61000-3-3 requirements.

This report applies to above tested sample only and shall not be reproduced in part without written approval of Shenzhen Anbotek Compliance Laboratory Limited.

Date of Receipt: Jan. 02, 2020

Date of Test: Jan. 02~09, 2020

Prepared By:

Yee Huang

(Yee Huang)

Approved & Authorized Signer:

KingKong Jin

(KingKong Jin)

1. General Information

1.1. Client Information

Applicant	:	Acrel Co.,Ltd.
Address	:	No.253, Yulv Road, Jiading District, Shanghai China
Manufacturer	:	Jiangsu Acrel Electrical Manufacturing. Co., Ltd.
Address	:	No.5, Dongmeng Road, Nanzha Street, Jiangyin City Jiangsu Province, China
Factory	:	Jiangsu Acrel Electrical Manufacturing. Co., Ltd.
Address	:	No.5, Dongmeng Road, Nanzha Street, Jiangyin City Jiangsu Province, China

1.2. Description of Device (EUT)

Product Name	:	Three-Phase Electric Meter
Model No.	:	ADL400,DTSD1352,ADL3000,DTSY1352,DTSF1352,ADL3000-E,ADL3000-EY,ADL3000-EF,ADL3000-EK,ADL3000-ET,ADL3000-EH,ADL3000-E2C,ADL3000-E/CT,ADL400,DTSD1352-*(Note: All samples are the same except the model number & appearance, so we prepare "ADL400" for test only.)
Trade Mark	:	Acrel
Test Power Supply	:	AC 400V, 50Hz
Test Sample No.	:	1-1-1
Product Description	:	Adapter: N/A
Remark: (1) For a more detailed features description, please refer to the manufacturer's specifications or the User's Manual. (2) As specified by the client, all the results in this report were quoted from report SZAHE200102002-01		

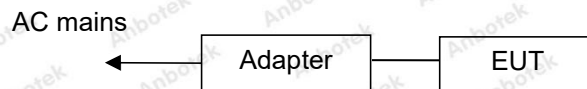
1.3. Auxiliary Equipment Used During Test

N/A	
-----	--

1.4. Description of Test Modes

Pretest Modes	Descriptions
Mode 1	Charging
Mode 2	Normal work

For Mode 1 Block Diagram of Test Setup



For Mode 2 Block Diagram of Test Setup



1.5. Test Summary

Test Items	Test Modes	Status
Power Line Conducted Emission Test (150KHz To 30MHz)	Mode 1	P
Radiated Emission Test (30MHz To 1000MHz)	Mode 1	P
Harmonic Current Test	/	N
Voltage Fluctuations and Flicker Test	/	N
Electrostatic Discharge immunity Test	Mode 1	P
RF Field Strength susceptibility Test	Mode 1	P
Electrical Fast Transient/Burst Immunity Test	Mode 1	P
Surge Immunity Test	Mode 1	P
Injected Currents Susceptibility Test	Mode 1	P
Magnetic Field Susceptibility Test	Mode 1	P
Voltage Dips and Interruptions Test	Mode 1	P
P) Indicates "PASS". N) Indicates "Not applicable".		

1.6. Test Equipment List

Conducted Emission Measurement

Item	Equipment	Manufacturer	Model No.	Serial No.	Last Cal.	Cal. Interval
1.	L.I.S.N. Artificial Mains Network	Rohde & Schwarz	ENV216	100055	Nov. 04,2019	1 Year
2.	L.I.S.N. Artificial Mains Network	Schwarzbeck	NSLK 8127	8127386	Nov. 04,2019	1 Year
3.	EMI Test Receiver	Rohde & Schwarz	ESCI	100627	Nov. 04,2019	1 Year
4.	RF Switching Unit	Compliance Direction	RSU-M2	38303	Nov. 04,2019	1 Year
5.	Software Name EZ-EMC	Ferrari Technology	ANB-03A	N/A	N/A	N/A

Radiated Emission Measurement

Item	Equipment	Manufacturer	Model No.	Serial No.	Last Cal.	Cal. Interval
1.	EMI Test Receiver	Rohde & Schwarz	ESCI	100627	Nov. 04,2019	1 Year
2.	Pre-amplifier	Schwarzbeck	BBV-9745	9745-075	Nov. 04,2019	1 Year
3.	Bilog Broadband Antenna	SCHWARZBECK	VULB 9163	01109	Nov. 01,2019	1 Year
4.	Software Name EZ-EMC	Ferrari Technology	EMEC-3A1	N/A	N/A	N/A

Electrostatic Discharge Measurement

Item	Equipment	Manufacturer	Model No.	Serial No.	Last Cal.	Cal. Interval
1.	ESD Simulators	3Ctest	EDS-30T	ES0131505	Nov. 06, 2019	1 Year

Electrical Fast Transient/Burst Immunity Measurement

Item	Equipment	Manufacturer	Model No.	Serial No.	Last Cal.	Cal. Interval
1.1	EFT Burst Simulator	PRIMA	EFT61004B	PR10114282	Nov. 04, 2019	1 Year
1.2	EFT-Clamp	PRIMA	EFT-Clamp	/	Nov. 04, 2019	1 Year
2.1	EFT Burst Simulator	TESEQ	NSG 3060	1480	Nov. 04, 2019	1 Year
2.2	CDN	TESEQ	CDN 3061	1408	Nov. 04, 2019	1 Year

R/S Immunity Measurement

Item	Equipment	Manufacturer	Model No.	Serial No.	Last Cal.	Cal. Interval
1	Signal Generator	Agilent	N5182A	MY4818065 6	Nov. 04, 2019	1 Year
2	Amplifier	Micotoop	MPA-80-100 0-250	MPA190309 6	N/A	N/A
3	Amplifier	Micotoop	MPA-1000-6 000-100	MPA190312 2	N/A	N/A
4	Log-Periodic Antenna	Schwarzbeck	VULP9118E	00992	Aug. 17, 2018	3 Year
5	Horn Antenna	Instruments corporation	GTH-0118	351600	Nov. 01, 2019	1 Year
6	Power Sensor	Agilent	E9301A	MY4149890 6	Nov. 04, 2019	1 Year
7	Power Sensor	Agilent	E9301A	MY4149808 8	Nov. 04, 2019	1 Year
8	Power Meter	Agilent	E4419B	GB4020290 9	Nov. 04, 2019	1 Year
9	Field Probe	ETS-Lindgren	HI-6006	00212747	Apr. 20, 2017	3 Year
10	software	EMtrace	EM 3	N/A	N/A	N/A

Surge Measurement

Item	Equipment	Manufacturer	Model No.	Serial No.	Last Cal.	Cal. Interval
1.	Surge Generator	TESEQ	NSG 3060	1480	Nov. 04, 2019	1 Year
2.	CDN	TESEQ	CDN 3061	1408	Nov. 04, 2019	1 Year
3.	Telecom port surge generator	PMI	TW101	190411	Apr.17,2019	1 Year

Injected Currents Susceptibility Measurement

Item	Equipment	Manufacturer	Model No.	Serial No.	Last Cal.	Cal. Interval
1.	C/S Conducted Immunity Test System	FRANKONIA	CIT-10	126A1196/20 12	Nov. 04, 2019	1 Year
2.	CDN	FRANKONIA	CDN - M2+ M3	A2210178/20 12	Nov. 04, 2019	1 Year
3.	6dB Attenuator	FRANKONIA	DAM 26W	1172202	Nov. 04, 2019	1 Year
4.	CIT-10	FRANKONIA	Version1.1.7	N/A	N.A	N/A

5.	EM-Clamp	FRANKONIA	EMCL-20	18101728-01 03	May.19,2019	1 Year
----	----------	-----------	---------	-------------------	-------------	--------

Voltage Dips and Interruptions Measurement

Item	Equipment	Manufacturer	Model No.	Serial No.	Last Cal.	Cal. Interval
1.	CYCLE SAG Simulator	PRIMA	DRP61011A G	PR12046234	Nov. 04, 2019	1 Year

M/S Measurement

Item	Equipment	Manufacturer	Model No.	Serial No.	Last Cal.	Cal. Interval
1.	Power Frequency Magnetic Field	EVERFINE	EMS61000-8	906002	Nov. 04, 2019	1 Year

1.7. Description of Test Facility

The test facility is recognized, certified, or accredited by the following organizations:

FCC-Registration No.: 184111

Shenzhen Anbotek Compliance Laboratory Limited, EMC Laboratory has been registered and fully described in a report filed with the (FCC) Federal Communications Commission. The acceptance letter from the FCC is maintained in our files.

Registration No. 184111

ISED-Registration No.: 8058A

Shenzhen Anbotek Compliance Laboratory Limited, EMC Laboratory has been registered and fully described in a report filed with the (ISED) Innovation, Science and Economic Development Canada. The acceptance letter from the ISED is maintained in our files.

Registration 8058A

Test Location

Shenzhen Anbotek Compliance Laboratory Limited.

1/F, Building D, Sogood Science and Technology Park, Sanwei community, Hangcheng Street, Bao'an District, Shenzhen, Guangdong, China.518128

1.8. EMS Performance Criteria

- ✓ A: Normal performance within the specification limits
- ✓ B: Temporary degradation or loss of function or performance which is self-recoverable
- ✓ C: Temporary degradation or loss of function or performance which requires operator intervention or system reset
- ✓ D: Degradation or loss of function which is not recoverable due to damage of equipment (components) or software, or loss of data

Note: The manufacturer's specification may define effects on the EUT which may be considered insignificant, and therefore acceptable.

This classification may be used as a guide in formulating performance criteria, by committees responsible for generic, product and product-family standards, or as a framework for the agreement on performance criteria between the manufacturer and the purchaser, for example where no suitable generic, product or product-family standard exists.

2. Power Line Conducted Emission Test

2.1. Test Standard and Limit

Test Standard	BS EN 61326-1
---------------	---------------

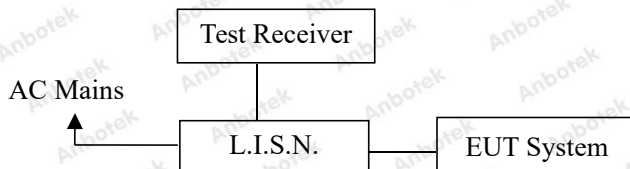
Limits for conducted emissions

Test Limit	Frequency (MHz)	At mains terminals (dB μ V)	
		Quasi-peak Level	Average Level
	0.15 ~ 0.50	79	66
	0.50 ~ 30.00	73	60

Remark: (1) The lower limit shall apply at the transition frequencies.

(2) The limit decreases linearly with the logarithm of the frequency in the range 0.15MHz to 0.50MHz.

2.2. Test Setup



2.3. EUT Configuration on Measurement

The following equipments are installed on Conducted Emission Measurement to meet BS EN 61326-1 requirements and operating in a manner which tends to maximize its emission characteristics in a normal application.

2.4. Operating Condition of EUT

2.4.1. Setup the EUT as shown in Section 2.2.

2.4.2. Turn on the power of all equipments.

2.4.3. Let the EUT work in test mode and measure it.

2.5. Test Procedure

The EUT is put on the table which is 0.8 meter high above the ground and connected to the AC mains through a Line Impedance Stabilization Network (L.I.S.N.). This provided a 50ohm coupling impedance for the tested equipments. Both sides of AC line are checked to find out the maximum conducted emission according to the BS EN 61326-1 regulations during conducted emission measurement. And the voltage probe had been used for the load terminals measurement according to the BS EN 61326-1 standard.

The bandwidth of the test receiver (ESCI) is set at 9KHZ in 150KHZ~30MHZ.

The frequency range from 150KHZ to 30MHZ is investigated for AC mains.

All the test results are listed in Section 2.6.

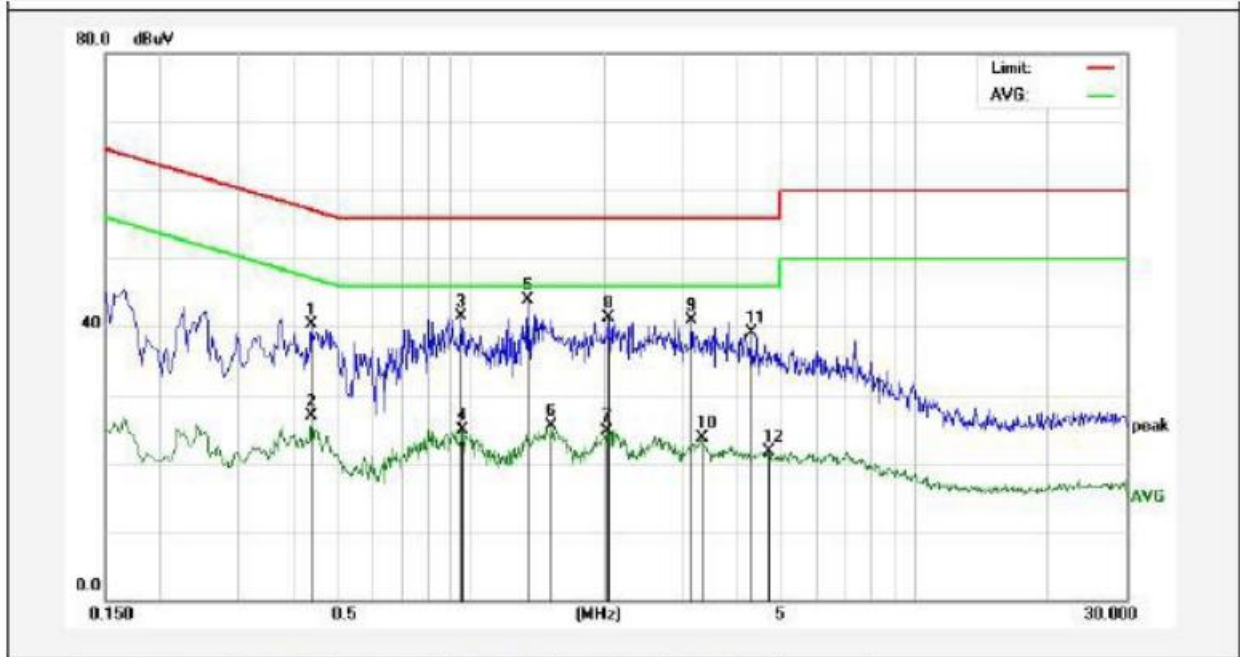
2.6. Test Results

PASS

The test curves are shown in the following pages.

Conducted Emission Test Data

Test Site: 1# Shielded Room
 Test Specification: AC 400V, 50Hz
 Comment: L1
 Temp.: 24.6°C Hum.: 48%

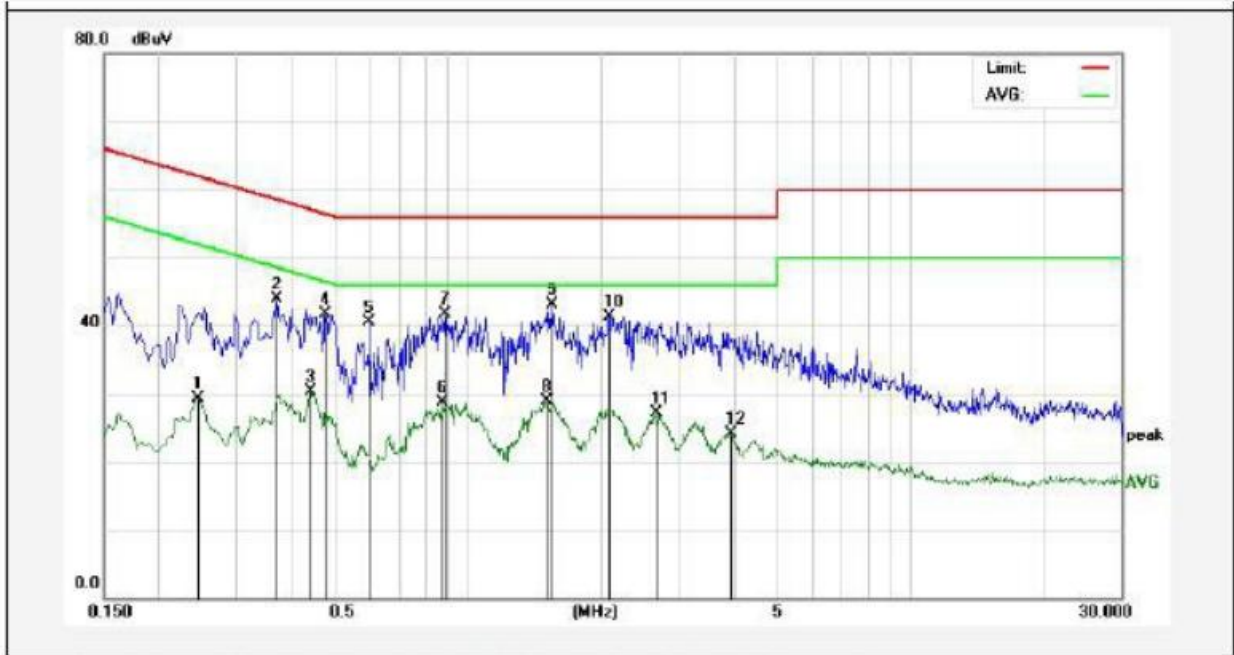


No.	Freq. (MHz)	Reading (dBuV)	Factor (dB)	Result (dBuV)	Limit (dBuV)	Over Limit (dB)	Detector	Remark
1	0.4380	20.38	19.95	40.33	57.10	-16.77	QP	
2	0.4380	7.03	19.95	26.98	47.10	-20.12	AVG	
3	0.9540	21.32	20.11	41.43	56.00	-14.57	QP	
4	0.9620	4.87	20.11	24.98	46.00	-21.02	AVG	
5	1.3460	23.69	20.13	43.82	56.00	-12.18	QP	
6	1.5260	5.38	20.13	25.51	46.00	-20.49	AVG	
7	2.0300	4.66	20.14	24.80	46.00	-21.20	AVG	
8	2.0340	21.10	20.14	41.24	56.00	-14.76	QP	
9	3.1420	20.81	20.16	40.97	56.00	-15.03	QP	
10	3.3180	3.51	20.17	23.68	46.00	-22.32	AVG	
11	4.2740	18.95	20.19	39.14	56.00	-16.86	QP	
12	4.7180	1.49	20.20	21.69	46.00	-24.31	AVG	

Note: Result=Reading+Factor Over Limit=Result-Limit

Conducted Emission Test Data

Test Site: 1# Shielded Room
 Test Specification: AC 400V, 50Hz
 Comment: L2
 Temp.: 24.6°C Hum.: 48%

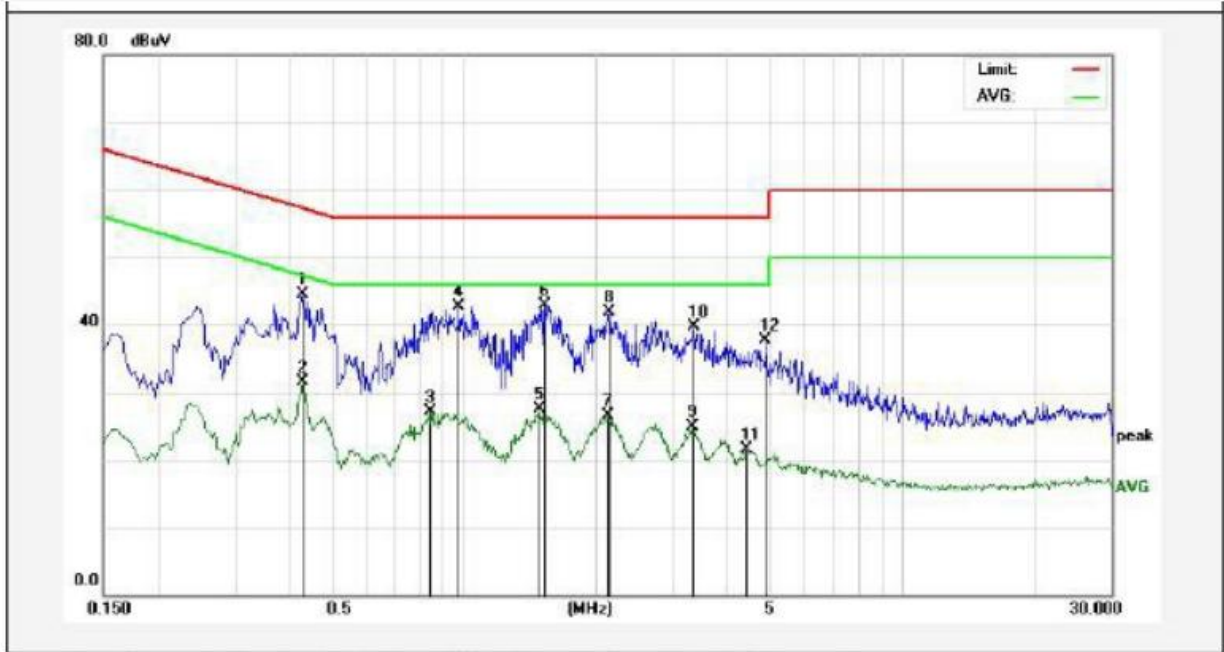


No.	Freq. (MHz)	Reading (dBuV)	Factor (dB)	Result (dBuV)	Limit (dBuV)	Over Limit (dB)	Detector	Remark
1	0.2460	9.49	19.89	29.38	51.89	-22.51	AVG	
2	0.3700	23.91	19.92	43.83	58.50	-14.67	QP	
3	0.4420	10.32	19.95	30.27	47.02	-16.75	AVG	
4	0.4780	21.82	19.97	41.79	56.37	-14.58	QP	
5	0.5980	20.46	20.01	40.47	56.00	-15.53	QP	
6	0.8780	8.56	20.09	28.65	46.00	-17.35	AVG	
7	0.8860	21.68	20.09	41.77	56.00	-14.23	QP	
8	1.5060	8.75	20.13	28.88	46.00	-17.12	AVG	
9	1.5540	22.98	20.13	43.11	56.00	-12.89	QP	
10	2.0780	21.11	20.14	41.25	56.00	-14.75	QP	
11	2.6700	7.02	20.15	27.17	46.00	-18.83	AVG	
12	3.9540	4.02	20.18	24.20	46.00	-21.80	AVG	

Note: Result=Reading+Factor Over Limit=Result-Limit

Conducted Emission Test Data

Test Site: 1# Shielded Room
 Test Specification: AC 400V, 50Hz
 Comment: L3
 Temp.: 24.6°C Hum.: 48%

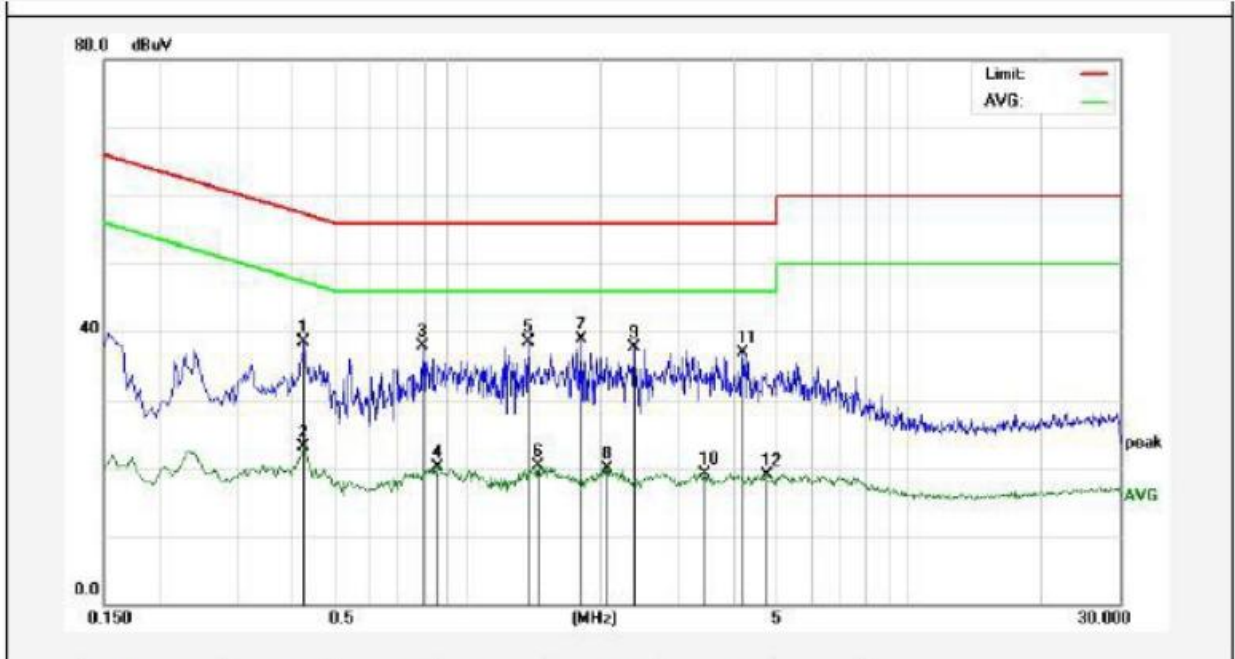


No.	Freq. (MHz)	Reading (dBuV)	Factor (dB)	Result (dBuV)	Limit (dBuV)	Over Limit (dB)	Detector	Remark
1	0.4300	24.64	19.95	44.59	57.25	-12.66	QP	
2	0.4300	11.53	19.95	31.48	47.25	-15.77	AVG	
3	0.8380	7.05	20.08	27.13	46.00	-18.87	AVG	
4	0.9780	22.56	20.11	42.67	56.00	-13.33	QP	
5	1.4860	7.44	20.13	27.57	46.00	-18.43	AVG	
6	1.5339	22.85	20.13	42.98	56.00	-13.02	QP	
7	2.1260	6.43	20.14	26.57	46.00	-19.43	AVG	
8	2.1500	21.83	20.14	41.97	56.00	-14.03	QP	
9	3.3180	4.82	20.17	24.99	46.00	-21.01	AVG	
10	3.3540	19.47	20.17	39.64	56.00	-16.36	QP	
11	4.4020	1.36	20.19	21.55	46.00	-24.45	AVG	
12	4.8980	17.55	20.20	37.75	56.00	-18.25	QP	

Note: Result=Reading+Factor Over Limit=Result-Limit

Conducted Emission Test Data

Test Site: 1# Shielded Room
 Test Specification: AC 400V, 50Hz
 Comment: N
 Temp.: 24.6°C Hum.: 48%



No.	Freq. (MHz)	Reading (dBuV)	Factor (dB)	Result (dBuV)	Limit (dBuV)	Over Limit (dB)	Detector	Remark
1	0.4260	18.64	19.95	38.59	57.33	-18.74	QP	
2	0.4260	3.23	19.95	23.18	47.33	-24.15	AVG	
3	0.7940	17.89	20.07	37.96	56.00	-18.04	QP	
4	0.8580	0.01	20.08	20.09	46.00	-25.91	AVG	
5	1.3779	18.40	20.13	38.53	56.00	-17.47	QP	
6	1.4460	0.09	20.13	20.22	46.00	-25.78	AVG	
7	1.8180	18.70	20.14	38.84	56.00	-17.16	QP	
8	2.0740	-0.18	20.14	19.96	46.00	-26.04	AVG	
9	2.3940	17.47	20.15	37.62	56.00	-18.38	QP	
10	3.4380	-1.12	20.17	19.05	46.00	-26.95	AVG	
11	4.2100	16.71	20.19	36.90	56.00	-19.10	QP	
12	4.7540	-1.21	20.20	18.99	46.00	-27.01	AVG	

Note: Result=Reading+Factor Over Limit=Result-Limit

3. Radiated Emission Test

3.1. Test Standard and Limit

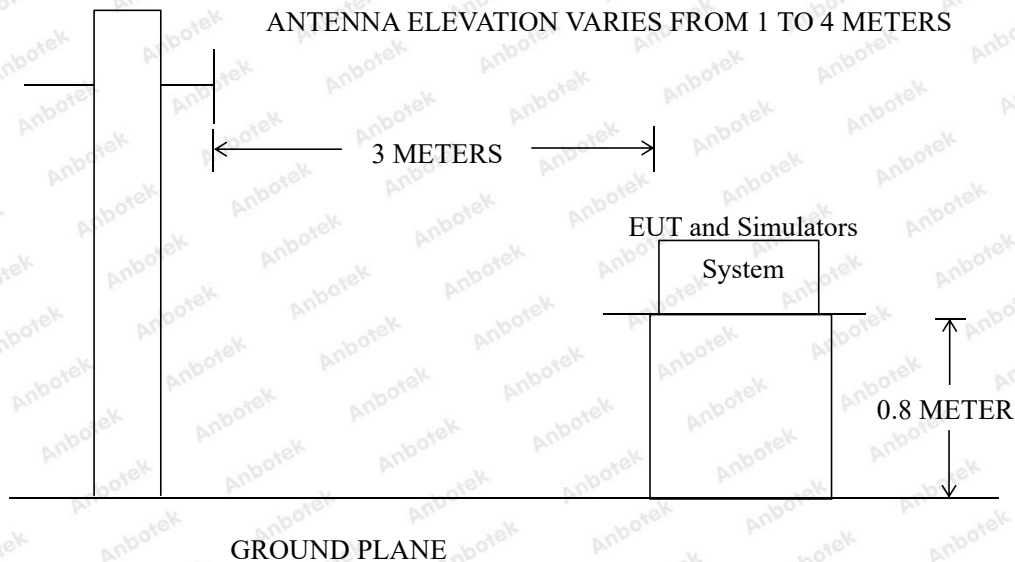
Test Standard	BS EN 61326-1
---------------	---------------

Radiated Emission Test Limit

Test Limit	Frequency (MHz)	DISTANCE (Meters)	FIELD STRENGTHS LIMIT (dB μ V/m)
	30 ~ 230	3	50
	230 ~ 1000	3	57

Remark: (1) The smaller limit shall apply at the combination point between two frequency bands.
 (2) Distance refers to the distance in meters between the measuring instrument antenna and the closed point of any part of the EUT.

3.2. Test Setup



3.3. EUT Configuration on Measurement

The BS EN 61326-1 regulations test method must be used to find the maximum emission during radiated emission measurement.

3.4. Operating Condition of EUT

- 3.4.1. Setup the EUT as shown in Section 3.2.
- 3.4.2. Turn on the power of all equipments.
- 3.4.3. Let the EUT work in test mode and measure it.

3.5. Test Procedure

The EUT is placed on a turn table which is 0.8 meter high above the ground. The turn table can rotate 360 degrees to determine the position of the maximum emission level. The EUT is set 3 meters away from the receiving antenna which is mounted on an antenna tower. The antenna can be moved up and down from 1 to 4 meters to find out the maximum emission level. Bilog antenna is used as a receiving antenna. Both horizontal and vertical polarization of the antenna are set on test.

The bandwidth of the Receiver (ESCI) is set at 120kHz.

The EUT is tested in Chamber.

The test results are listed in Section 3.6.

3.6. Test Results

PASS

The frequency range from 30MHz to 1000MHz is investigated.

The test curves are shown in the following pages.

Test item: Radiation Test **Polarization:** Horizontal
Standard: (RE)BS EN61326-1 **Power Source:** AC 400V, 50Hz
Distance: 3m **Temp.(°C)/Hum.(%RH):** 22.6(°C)/57%RH
Test Mode:



No.	Freq. (MHz)	Reading (dBuV)	Factor ()	Result (dBuV/m)	Limit (dBuV/m)	Over Limit (dB)	Detector	Height (cm)	degree (deg)	Remark
1	85.1486	43.76	-21.71	22.05	40.00	-17.95	peak			
2	125.2260	53.62	-24.49	29.13	40.00	-10.87	peak			
3	164.5271	59.73	-23.29	36.44	40.00	-3.56	QP	100	360	
4	173.2051	59.31	-22.63	36.68	40.00	-3.32	QP	100	0	
5	243.8043	51.81	-20.38	31.43	47.00	-15.57	peak			
6	331.3546	45.10	-17.33	27.77	47.00	-19.23	peak			

Note: **Result=Reading+Factor** **Over Limit=Result-Limit**

Test item: Radiation Test **Polarization:** Vertical
Standard: (RE)BS EN61326-1 **Power Source:** AC 400V, 50Hz
Distance: 3m **Temp.(°C)/Hum.(%RH):** 22.6(°C)/57%RH
Test Mode:



No.	Freq. (MHz)	Reading (dBuV)	Factor ()	Result (dBuV/m)	Limit (dBuV/m)	Over Limit (dB)	Detector	Height (cm)	degree (deg)	Remark
1	32.7486	48.25	-16.84	31.41	40.00	-8.59	peak			
2	53.9763	45.69	-16.07	29.62	40.00	-10.38	peak			
3	80.7857	38.96	-20.16	18.80	40.00	-21.20	peak			
4	127.4409	47.68	-19.39	28.29	40.00	-11.71	peak			
5	167.7868	53.63	-19.63	34.00	40.00	-6.00	QP	100	360	
6	243.8043	44.64	-16.19	28.45	47.00	-18.55	peak			

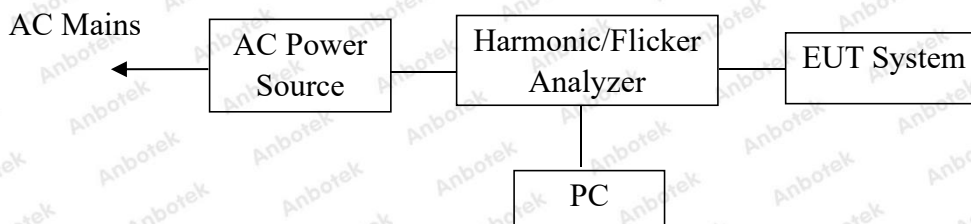
Note: **Result=Reading+Factor** **Over Limit=Result-Limit**

4. Harmonic Current Emission Test

4.1. Test Standard

Test Standard	BS EN IEC 61000-3-2
---------------	---------------------

4.2. Test Setup



4.3. Operating Condition of EUT

- 4.3.1. Setup the EUT as shown on Section 4.2.
- 4.3.2. Turn on the power of all equipments.
- 4.3.3. After that, let the EUT work in test mode measure it.

4.4. Test Results

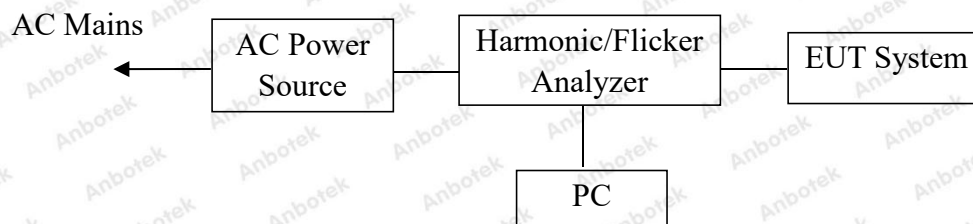
PASS

5. Voltage Fluctuations & Flicker Test

5.1. Test Standard

Test Standard	BS EN 61000-3-3
---------------	-----------------

5.2. Test Setup



5.3. Operating Condition of EUT

5.3.1. Setup the EUT as shown on Section 5.2.

5.3.2. Turn on the power of all equipments.

5.3.3. After that, let the EUT work in test mode measure it.

5.4. Test Results

PASS

6. Electrostatic Discharge Immunity Test

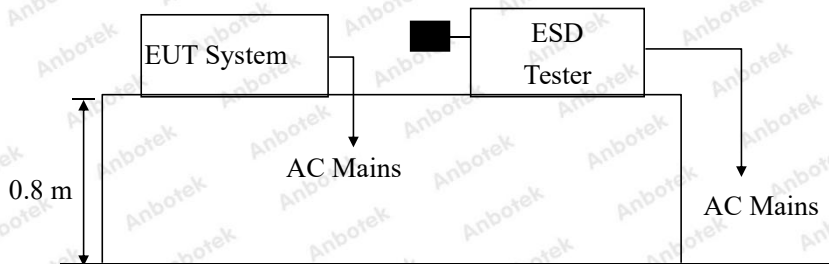
6.1. Test Standard and Level

Test Standard:	BS EN 61326-1 (IEC 61000-4-2)
Performance Criterion:	B
Severity Level: 3 / Air Discharge: $\pm 8\text{kV}$, Level: 2 / Contact Discharge: $\pm 4\text{kV}$	

Test Level

Level	Test Voltage Contact Discharge (kV)	Test Voltage Air Discharge (kV)
1.	± 2	± 2
2.	± 4	± 4
3.	± 6	± 8
4.	± 8	± 15
X.	Special	Special

6.2. Test Setup



6.3. EUT Configuration on Measurement

The following equipments are installed on Electrostatic Discharge immunity Measurement to meet BS EN 61326-1 requirements and operating in a manner which tends to maximize its emission characteristics in a normal application.

6.4. Operating Condition of EUT

- 6.4.1. Setup the EUT as shown on Section 6.2.
- 6.4.2. Turn on the power of all equipments.
- 6.4.3. After that, let the EUT work in test mode measure it.

6.5. Test Procedure

6.5.1. Air Discharge:

This test is done on a non-conductive surface. The round discharge tip of the discharge electrode shall be approached as fast as possible to touch the EUT. After each discharge, the discharge electrode shall be removed from the EUT. The generator is then re-triggered for a new single discharge and repeated 10 times for each pre-selected test point. This procedure shall be repeated until all the air discharge completed.

6.5.2. Contact Discharge:

All the procedure shall be same as Section 6.5.1. except that the tip of the discharge electrode shall touch the EUT before the discharge switch is operated.

6.5.3. Indirect discharge for horizontal coupling plane

At least 20 single discharges shall be applied to the horizontal coupling plane, at points on each side of the EUT. The discharge electrode positions vertically at a distance of 0.1m from the EUT and with the discharge electrode touching the coupling plane.

6.5.4. Indirect discharge for vertical coupling plane

At least 20 single discharge shall be applied to the center of one vertical edge of the coupling plane. The coupling plane, of dimensions 0.5m × 0.5m, is placed parallel to, and positioned at a distance of 0.1m from the EUT. Discharges shall be applied to the coupling plane, with this plane in sufficient different positions that the four faces of the EUT are completely illuminated.

6.6. Test Results

PASS

Please refer to the following page.



Electrostatic Discharge Test Results

Air discharge :	±8.0kV	Temperature :	23.5°C
Contact discharge :	±4.0kV	Humidity :	50%
Power Supply :	AC 400V, 50Hz	Expert conclusion:	A
Test Result :	<input checked="" type="checkbox"/> Pass <input type="checkbox"/> Fail		

For each point positive 10 times and negative 10 times discharge

Location		Kind A-Air Discharge C-Contact Discharge	Result
Slot	6 points	A	<input checked="" type="checkbox"/> A <input type="checkbox"/> B <input type="checkbox"/> C <input type="checkbox"/> D
Screen	2 points	A	<input checked="" type="checkbox"/> A <input type="checkbox"/> B <input type="checkbox"/> C <input type="checkbox"/> D
Button	4 points	A	<input checked="" type="checkbox"/> A <input type="checkbox"/> B <input type="checkbox"/> C <input type="checkbox"/> D
Screw	8 points	A	<input checked="" type="checkbox"/> A <input type="checkbox"/> B <input type="checkbox"/> C <input type="checkbox"/> D
Light	2 points	A	<input checked="" type="checkbox"/> A <input type="checkbox"/> B <input type="checkbox"/> C <input type="checkbox"/> D
HCP	4 points	C	<input type="checkbox"/> A <input type="checkbox"/> B <input checked="" type="checkbox"/> C <input type="checkbox"/> D
VCP of the front	4 points	C	<input type="checkbox"/> A <input type="checkbox"/> B <input checked="" type="checkbox"/> C <input type="checkbox"/> D
VCP of the rear	4 points	C	<input type="checkbox"/> A <input type="checkbox"/> B <input checked="" type="checkbox"/> C <input type="checkbox"/> D
VCP of the left	4 points	C	<input type="checkbox"/> A <input type="checkbox"/> B <input checked="" type="checkbox"/> C <input type="checkbox"/> D
VCP of the right	4 points	C	<input type="checkbox"/> A <input type="checkbox"/> B <input checked="" type="checkbox"/> C <input type="checkbox"/> D

Remark: Discharge should be considered on Contact and Air and Horizontal Coupling Plane (HCP) and Vertical Coupling Plane (VCP).

7. RF Field Strength Susceptibility Test

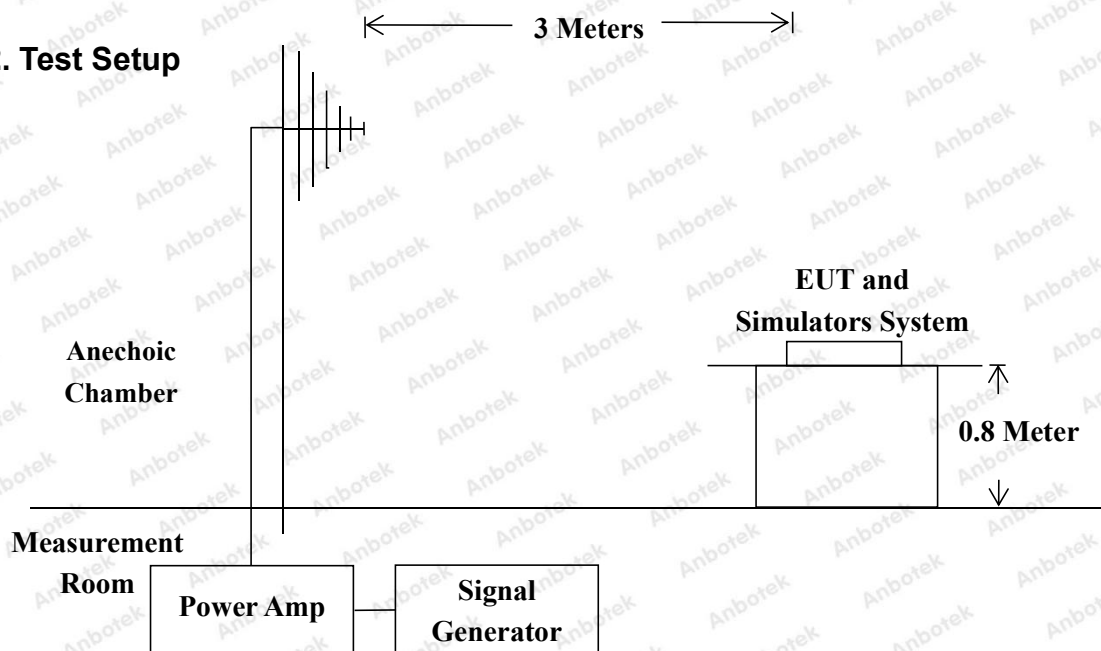
7.1. Test Standard and Level

Test Standard:	BS EN 61326-1 (IEC 61000-4-3)
Required Performance:	A
Frequency Range:	80MHz to 1000MHz/ 1.4GHz to 2.0GHz/ 2.0GHz to 2.7GHz
Field Strength:	3V/m, 3V/m, 1V/m
Modulation:	1kHz Sine Wave, 80%, AM Modulation
Frequency Step:	1 % of preceding frequency value
Polarity of Antenna:	Horizontal and Vertical
Test Distance:	3 m
Antenna Height:	1.5 m
Dwell Time:	at least 0.5s

Test Level

Level	Field Strength V/m
1.	1
2.	3
3.	10
X.	Special

7.2. Test Setup



7.3. EUT Configuration on Measurement

The following equipments are installed on RF Field Strength susceptibility Measurement to meet BS EN 61326-1 requirements and operating in a manner which tends to maximize its emission characteristics in a normal application.

7.4. Operating Condition of EUT

7.4.1. Setup the EUT as shown on Section 7.2.

7.4.2. Turn on the power of all equipments.

7.4.3. After that, let the EUT work in test mode measure it.

7.5. Test Procedure

The EUT and support equipment, which are placed on a table that is 0.8 meter above ground and the testing was performed in a fully-anechoic chamber. The testing distance from antenna to the EUT was 3 meters.

- 1) 80 MHz to 1000 MHz the field strength level was 3V/m, 1.4 GHz to 2.0 GHz the field strength level was 3V/m, 2.0 GHz to 2.7 GHz the field strength level was 1V/m.
- 2) The frequency range is swept from 80 MHz to 1000 MHz, 1.4 GHz to 2.0 GHz, 2.0 GHz to 2.7 GHz with the signal 80% amplitude modulated with a 1kHz sine wave.
- 3) The dwell time at each frequency shall be not less than the time necessary for the EUT to be able to respond, but shall in no case be less than 0.5s.
- 4) The test was performed with the EUT exposed to both vertically and horizontally polarized fields on each of the four sides.

7.6. Measuring Results

PASS

Please refer to the following page.

RF Field Strength Susceptibility Test Results

Field Strength :	10 V/m, 3V/m, 1V/m	Temperature :	23.5°C
Expert conclusion:	A	Humidity :	50%
Power Supply :	AC 400V, 50Hz	Test Result :	<input checked="" type="checkbox"/> Pass <input type="checkbox"/> Fail
Dwell Time:	1s		

Frequency Range	Antenna Polarity	R.F. Field Strength	Azimuth	Result
80MHz~1000MHz	H / V	10 V/m (rms)	Front	<input checked="" type="checkbox"/> A <input type="checkbox"/> B <input type="checkbox"/> C <input type="checkbox"/> D
			Rear	
			Left	
			Right	
1.4GHz~2.0GHz	H / V	3 V/m (rms)	Front	<input checked="" type="checkbox"/> A <input type="checkbox"/> B <input type="checkbox"/> C <input type="checkbox"/> D
			Rear	
			Left	
			Right	
2.0GHz~2.7GHz	H / V	1 V/m (rms)	Front	<input checked="" type="checkbox"/> A <input type="checkbox"/> B <input type="checkbox"/> C <input type="checkbox"/> D
			Rear	
			Left	
			Right	

8. Electrical Fast Transient/Burst Immunity Test

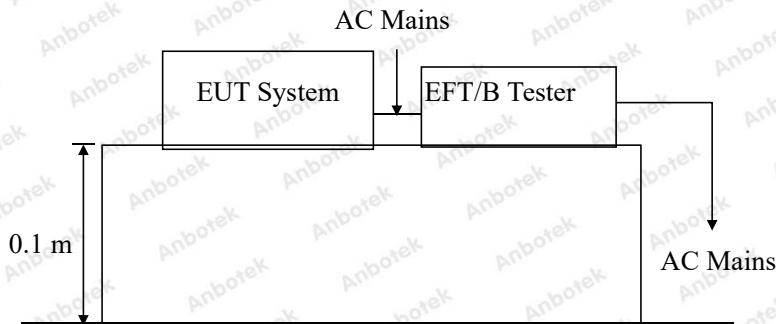
8.1. Test Standard and Level

Test Standard:	BS EN 61326-1 (IEC 61000-4-4)
Performance criterion:	B
Severity Level 2: 1.00kV	

Test Level

Open Circuit Output Test Voltage $\pm 10\%$		
Level	On Power Supply Lines	On I/O (Input/Output) Signal data and control lines
1.	0.50 kV	0.25 kV
2.	1.00 kV	0.50 kV
3.	2.00 kV	1.00 kV
4.	4.00 kV	2.00 kV
X.	Special	Special

8.2. Test Setup



8.3. EUT Configuration on Measurement

The following equipments are installed on Electrical Fast Transient/Burst Immunity Measurement to meet BS EN 61326-1 requirements and operating in a manner which tends to maximize its emission characteristics in a normal application.

8.4. Operating Condition of EUT

- 8.4.1. Setup the EUT as shown in Section 8.2.
- 8.4.2. Turn on the power of all equipments.
- 8.4.3. Let the EUT work in test mode and measure it.

8.5. Test Procedure

The EUT is put on the table which is 0.1 meter high above the ground. This reference ground plane shall project beyond the EUT by at least 0.1m on all sides and the minimum distance between EUT and all other conductive structure, except the ground plane beneath the EUT, shall be more than 0.5m.

8.5.1. For input and output AC power ports:

The EUT is connected to the power mains by using a coupling device which couples the EFT interference signal to AC power lines. Both polarities of the test voltage should be applied during compliance test and the duration of the test is 2 mins.

8.5.2. For signal lines and control lines ports:

Select tests based on product characteristics.

8.5.3. For DC output line ports:

Select tests based on product characteristics.

8.6. Test Results

PASS

Please refer to the following page.

Electrical Fast Transient/Burst Test Results

Ambient Condition : 23.5°C / 50% RH		Expert conclusion: A	
Power Supply : AC 400V, 50Hz		Test Result : <input checked="" type="checkbox"/> Pass <input type="checkbox"/> Fail	
Inject Line : AC Mains		Inject Method: Direct	Inject Time(s): 120
Line	Polarity	Test Voltage (kV)	Result
L1	±	1.00kV	<input checked="" type="checkbox"/> A <input type="checkbox"/> B <input type="checkbox"/> C <input type="checkbox"/> D
L2	±	1.00kV	<input checked="" type="checkbox"/> A <input type="checkbox"/> B <input type="checkbox"/> C <input type="checkbox"/> D
L3	±	1.00kV	<input checked="" type="checkbox"/> A <input type="checkbox"/> B <input type="checkbox"/> C <input type="checkbox"/> D
N	±	1.00kV	<input checked="" type="checkbox"/> A <input type="checkbox"/> B <input type="checkbox"/> C <input type="checkbox"/> D
L1、L2	±	1.00kV	<input checked="" type="checkbox"/> A <input type="checkbox"/> B <input type="checkbox"/> C <input type="checkbox"/> D
L1、L3	±	1.00kV	<input checked="" type="checkbox"/> A <input type="checkbox"/> B <input type="checkbox"/> C <input type="checkbox"/> D
L2、L3	±	1.00kV	<input checked="" type="checkbox"/> A <input type="checkbox"/> B <input type="checkbox"/> C <input type="checkbox"/> D
L1、N	±	1.00kV	<input checked="" type="checkbox"/> A <input type="checkbox"/> B <input type="checkbox"/> C <input type="checkbox"/> D
L2、N	±	1.00kV	<input checked="" type="checkbox"/> A <input type="checkbox"/> B <input type="checkbox"/> C <input type="checkbox"/> D
L3、N	±	1.00kV	<input checked="" type="checkbox"/> A <input type="checkbox"/> B <input type="checkbox"/> C <input type="checkbox"/> D
L1、L2、N	±	1.00kV	<input checked="" type="checkbox"/> A <input type="checkbox"/> B <input type="checkbox"/> C <input type="checkbox"/> D
L1、L3、N	±	1.00kV	<input checked="" type="checkbox"/> A <input type="checkbox"/> B <input type="checkbox"/> C <input type="checkbox"/> D
L2、L3、N	±	1.00kV	<input checked="" type="checkbox"/> A <input type="checkbox"/> B <input type="checkbox"/> C <input type="checkbox"/> D
DC Line			
Signal Line			

9. Surge Immunity Test

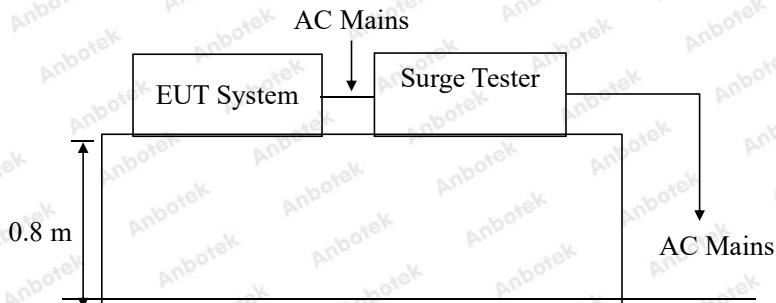
9.1. Test Standard and Level

Test Standard:	BS EN EN 61326-1 (IEC 61000-4-5)
Performance criterion:	B
Severity Level: Level 1, Line to Line: 0.5kV	

Test Level

Severity Level	Open-Circuit Test Voltage (kV)
1.	0.5
2.	1.0
3.	2.0
4.	4.0
X.	Special

9.2. Test Setup



9.3. EUT Configuration on Measurement

The following equipments are installed on Surge immunity Measurement to meet BS EN 61326-1 requirements and operating in a manner which tends to maximize its emission characteristics in a normal application.

9.4. Operating Condition of EUT

9.4.1. Setup the EUT as shown in Section 9.2.

9.4.2. Turn on the power of all equipments.

9.4.3. Let the EUT work in test mode and measure it.

9.5. Test Procedure

9.5.1. Set up the EUT and test generator as shown on Section 9.2.

9.5.2. For line to line coupling mode, provide a 0.5 kV 1.2/50us voltage surge (at open-circuit condition) and 8/20us current surge to EUT selected points.

9.5.3. At least 5 positive and 5 negative (polarity) tests with a maximum 1/min repetition rate are conducted during test.

9.5.4. Different phase angles are done individually.

9.5.5. Record the EUT operating situation during compliance test and decide the EUT immunity criterion for above each test.

9.6. Test Results

PASS

Please refer to the following page.



Surge Immunity Test Results

Humidity :	50%		Temperature :	23.5°C	
Power Supply :	AC 400V, 50Hz		Criterion required:	A	
Test Result :	<input checked="" type="checkbox"/> Pass <input type="checkbox"/> Fail				
Location	Polarity	Phase Angle	Number of Pulse	Pulse Voltage (kV)	Performance Criterion
L1-L2	±	<input checked="" type="checkbox"/> 0° <input checked="" type="checkbox"/> 90° <input checked="" type="checkbox"/> 180° <input checked="" type="checkbox"/> 270°	5	1.0	<input checked="" type="checkbox"/> A <input type="checkbox"/> B <input type="checkbox"/> C <input type="checkbox"/> D
L1-L3	±	<input checked="" type="checkbox"/> 0° <input checked="" type="checkbox"/> 90° <input checked="" type="checkbox"/> 180° <input checked="" type="checkbox"/> 270°	5	1.0	<input checked="" type="checkbox"/> A <input type="checkbox"/> B <input type="checkbox"/> C <input type="checkbox"/> D
L1-N	±	<input checked="" type="checkbox"/> 0° <input checked="" type="checkbox"/> 90° <input checked="" type="checkbox"/> 180° <input checked="" type="checkbox"/> 270°	5	1.0	<input checked="" type="checkbox"/> A <input type="checkbox"/> B <input type="checkbox"/> C <input type="checkbox"/> D
L2-L3	±	<input checked="" type="checkbox"/> 0° <input checked="" type="checkbox"/> 90° <input checked="" type="checkbox"/> 180° <input checked="" type="checkbox"/> 270°	5	1.0	<input checked="" type="checkbox"/> A <input type="checkbox"/> B <input type="checkbox"/> C <input type="checkbox"/> D
L2-N	±	<input checked="" type="checkbox"/> 0° <input checked="" type="checkbox"/> 90° <input checked="" type="checkbox"/> 180° <input checked="" type="checkbox"/> 270°	5	1.0	<input checked="" type="checkbox"/> A <input type="checkbox"/> B <input type="checkbox"/> C <input type="checkbox"/> D
L3-N	±	<input checked="" type="checkbox"/> 0° <input checked="" type="checkbox"/> 90° <input checked="" type="checkbox"/> 180° <input checked="" type="checkbox"/> 270°	5	1.0	<input checked="" type="checkbox"/> A <input type="checkbox"/> B <input type="checkbox"/> C <input type="checkbox"/> D
L1-PE	±	<input checked="" type="checkbox"/> 0° <input checked="" type="checkbox"/> 90° <input checked="" type="checkbox"/> 180° <input checked="" type="checkbox"/> 270°	5	2.0	<input checked="" type="checkbox"/> A <input type="checkbox"/> B <input type="checkbox"/> C <input type="checkbox"/> D
L2-PE	±	<input checked="" type="checkbox"/> 0° <input checked="" type="checkbox"/> 90° <input checked="" type="checkbox"/> 180° <input checked="" type="checkbox"/> 270°	5	2.0	<input checked="" type="checkbox"/> A <input type="checkbox"/> B <input type="checkbox"/> C <input type="checkbox"/> D
L3-PE	±	<input checked="" type="checkbox"/> 0° <input checked="" type="checkbox"/> 90° <input checked="" type="checkbox"/> 180° <input checked="" type="checkbox"/> 270°	5	2.0	<input checked="" type="checkbox"/> A <input type="checkbox"/> B <input type="checkbox"/> C <input type="checkbox"/> D
N-PE	±	<input checked="" type="checkbox"/> 0° <input checked="" type="checkbox"/> 90° <input checked="" type="checkbox"/> 180° <input checked="" type="checkbox"/> 270°	5	2.0	<input checked="" type="checkbox"/> A <input type="checkbox"/> B <input type="checkbox"/> C <input type="checkbox"/> D

10. Injected Currents Susceptibility Test

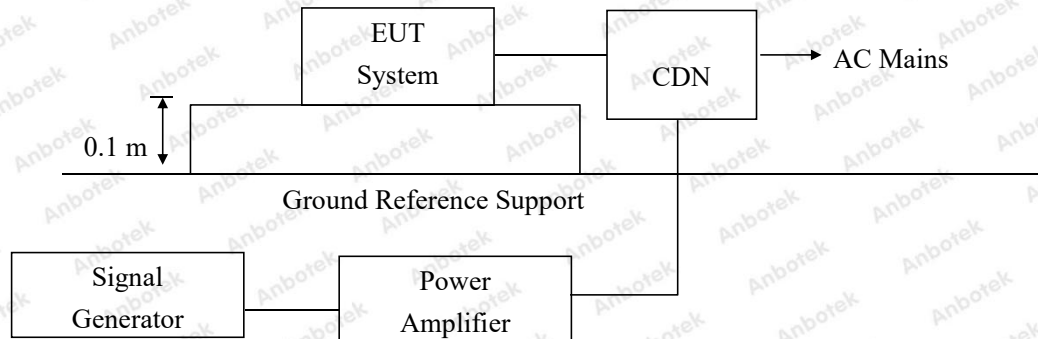
10.1. Test Standard and Level

Test Standard	BS EN 61326-1 (IEC 61000-4-6)
Performance criterion	A
Severity Level 2: 3V (rms), (0.15MHz ~80MHz)	

Test Level

Level	Field Strength V
1.	1
2.	3
3.	10
X.	Special

10.2. Test Setup



10.3. EUT Configuration

The following equipments are installed on currents susceptibility Measurement to meet BS EN 61326-1 requirements and operating in a manner which tends to maximize its emission characteristics in a normal application.

10.4. Operating Condition of EUT

- 10.4.1. Setup the EUT as shown in Section 10.2.
- 10.4.2. Turn on the power of all equipments.
- 10.4.3. Let the EUT work in test mode and measure it.

10.5. Test Procedure

- 1) Set up the EUT, CDN and test generators as shown on Section 10.2.
- 2) Let the EUT work in test mode and measure it.
- 3) The EUT are placed on an insulating support 0.1m high above a ground reference plane. CDN (coupling and decoupling device) is placed on the ground plane about 0.3m from EUT. Cables between CDN and EUT are as short as possible, and their height above the ground reference plane shall be between 30 and 50 mm (where possible).
- 4) The disturbance signal described below is injected to EUT through CDN.
- 5) The EUT operates within its operational mode(s) under intended climatic conditions after power on.
- 6) The frequency range is swept from 150KHz to 80MHz using 3V signal level, and with the disturbance signal 80% amplitude modulated with a 1KHz sine wave.
- 7) The rate of sweep shall not exceed $1.5 \cdot 10^{-3}$ decades/s. Where the frequency is swept incrementally, the step size shall not exceed 1% of the start and thereafter 1% of the preceding frequency value.
- 8) Recording the EUT operating situation during compliance testing and decide the EUT immunity criterion.

10.6. Test Results

PASS

Please refer to the following page.



Injected Currents Susceptibility Test Results

Humidity : 50%		Temperature : 23.5°C	
Power Supply : AC 400V, 50Hz		Expert conclusion: A	
Test Result : <input checked="" type="checkbox"/> Pass <input type="checkbox"/> Fail			
Frequency Range (MHz)	Injected Position	Strength (Unmodulated)	Result
0.15 ~ 80	AC Mains	3V	<input checked="" type="checkbox"/> A <input type="checkbox"/> B <input type="checkbox"/> C <input type="checkbox"/> D
Remark : 1. Modulation Signal:1KHz 80% AM			

11. Voltage Dips And Interruptions Test

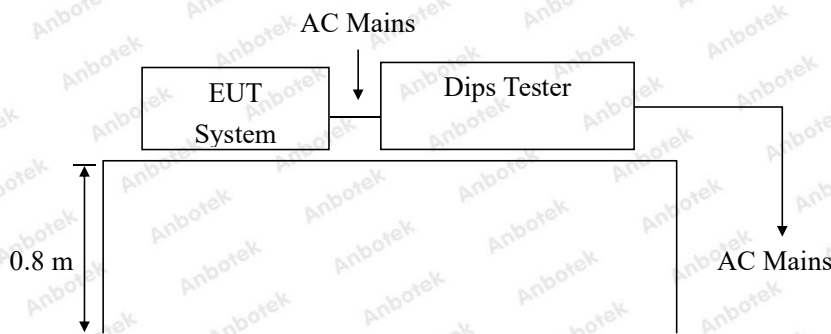
11.1. Test Standard and Level

Test Standard:	BS EN 61326-1 (IEC 61000-4-11)
Performance Criterion:	B&C

Test Level

Test Level %UT	Voltage dip and short interruptions %UT	Duration (in period)
0	100	0.5 1 5 10 25 50 *
40	60	
70	30	
0	100	

11.2. Test Setup



11.3. EUT Configuration on Measurement

The following equipments are installed on Voltage dips and interruptions Measurement to meet BS EN 61326-1 requirements and operating in a manner which tends to maximize its emission characteristics in a normal application.

11.4. Operating Condition of EUT

- 11.4.1. Setup the EUT as shown in Section 11.2.
- 11.4.2. Turn on the power of all equipments.
- 11.4.3. Let the EUT work in test mode and measure it.

11.5. Test Procedure

- 1) Set up the EUT and test generator as shown on Section 11.2.
- 2) The interruptions is introduced at selected phase angles with specified duration.
- 3) Record any degradation of performance.

11.6. Test Results

PASS

Please refer to the following page.



Voltage Dips and Interruptions Test Results

Temperature : 23.5°C		Humidity : 50%	
Power Supply : AC 400V, 50Hz		Expert conclusion: B&C	
Test Result : <input checked="" type="checkbox"/> Pass <input type="checkbox"/> Fail			
Test Level % UT	Voltage Dips & Short Interruptions % UT	Duration (in periods)	Result
0	100	0.5P	<input type="checkbox"/> A <input checked="" type="checkbox"/> B <input type="checkbox"/> C <input type="checkbox"/> D
0	100	1.0P	<input type="checkbox"/> A <input type="checkbox"/> B <input checked="" type="checkbox"/> C <input type="checkbox"/> D
70	30	25P	<input type="checkbox"/> A <input type="checkbox"/> B <input checked="" type="checkbox"/> C <input type="checkbox"/> D
0	100	250P	<input type="checkbox"/> A <input type="checkbox"/> B <input checked="" type="checkbox"/> C <input type="checkbox"/> D
Test Level % UT	Voltage Dips & Short Interruptions % UT	Duration (in periods)	Result

APPENDIX I -- TEST SETUP PHOTOGRAPH

Photo of Power Line Conducted Emission Test



Photo of Radiated Emission Test



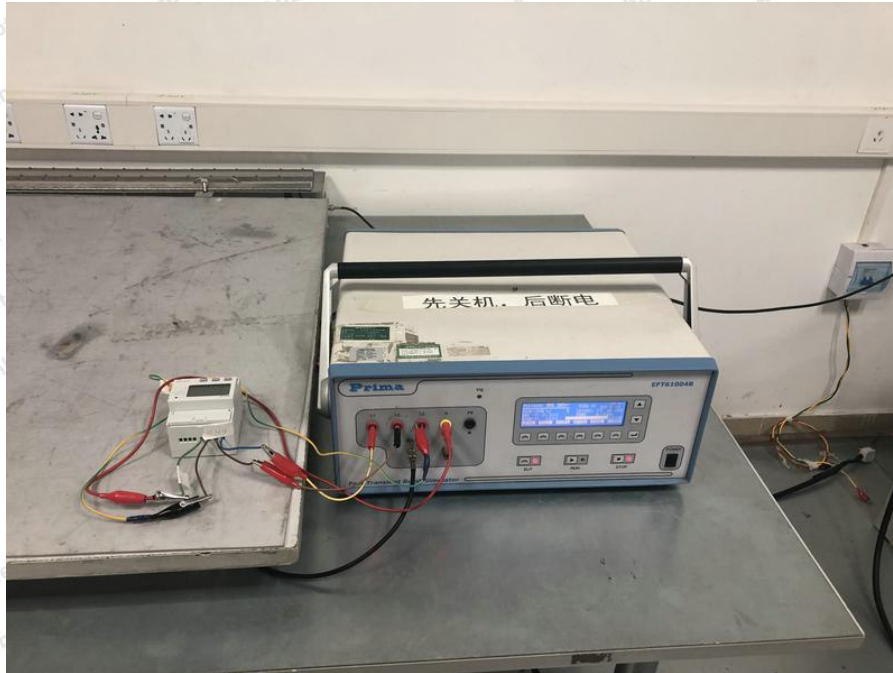
Photo of Electrostatic Discharge Immunity Test



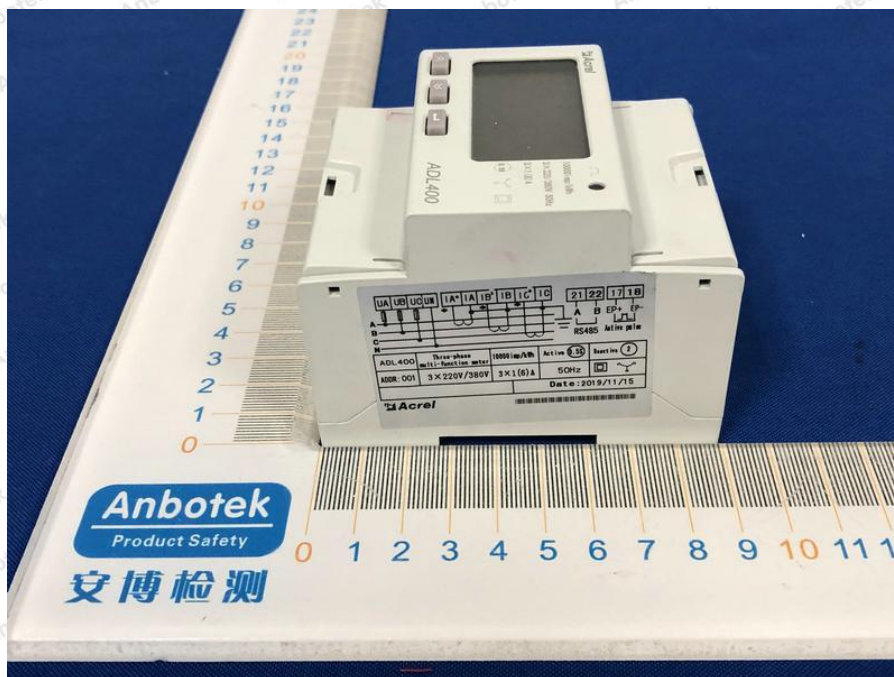
Photo of RF Field Strength susceptibility Test

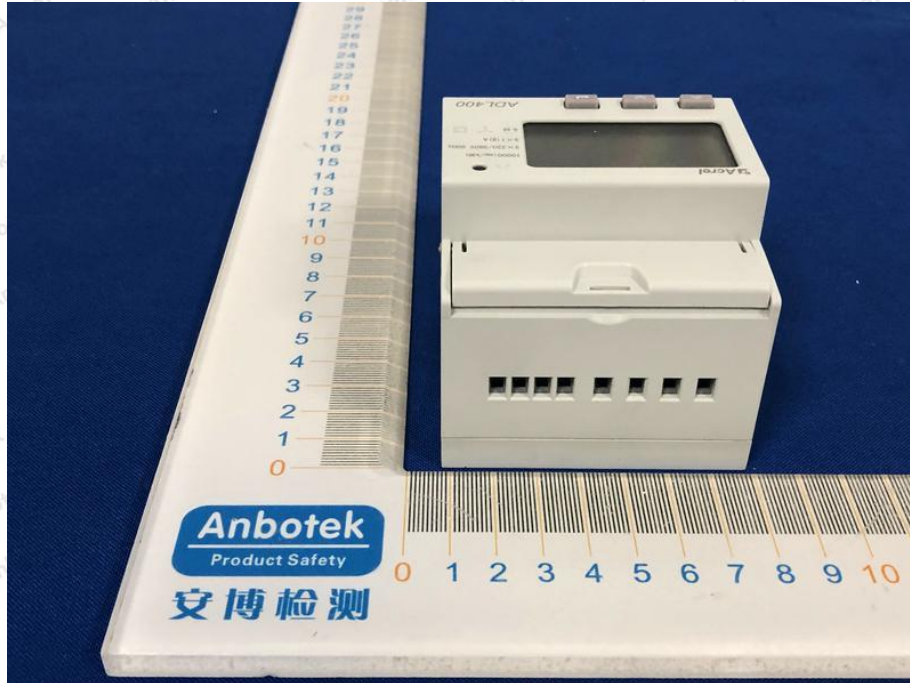


Photo of Electrical Fast Transient/Burst Immunity Test

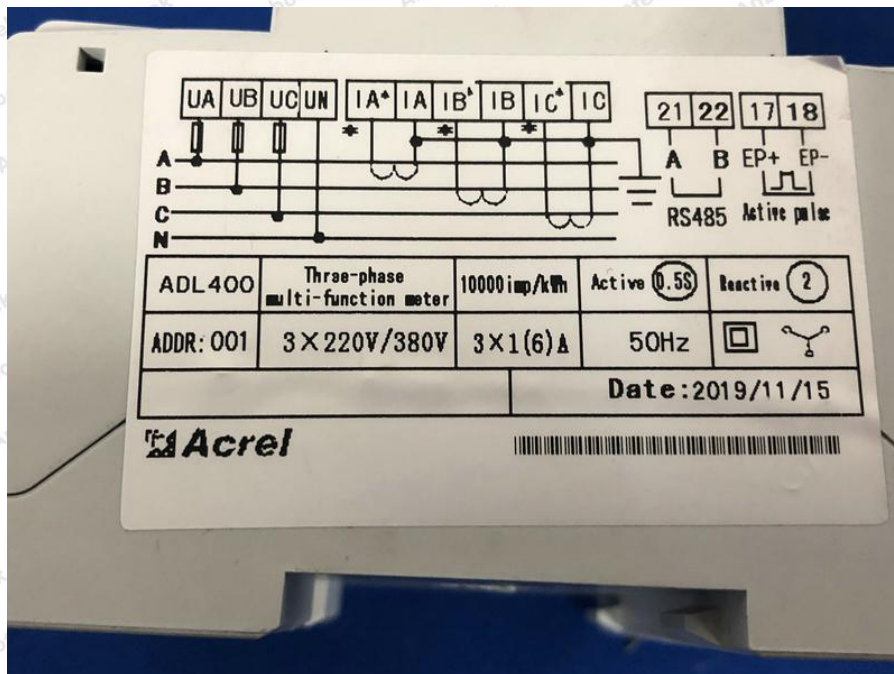
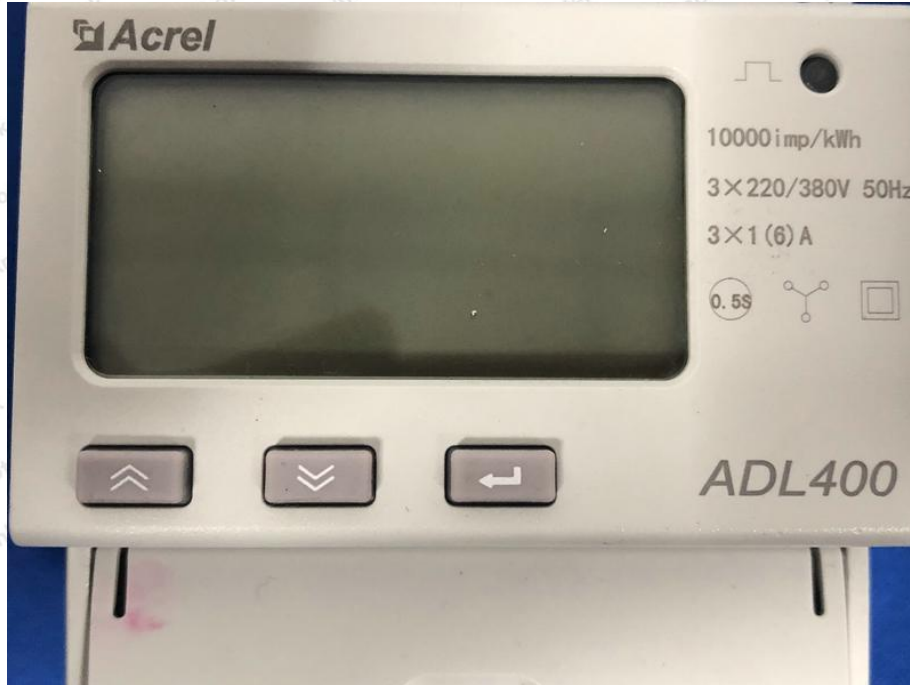


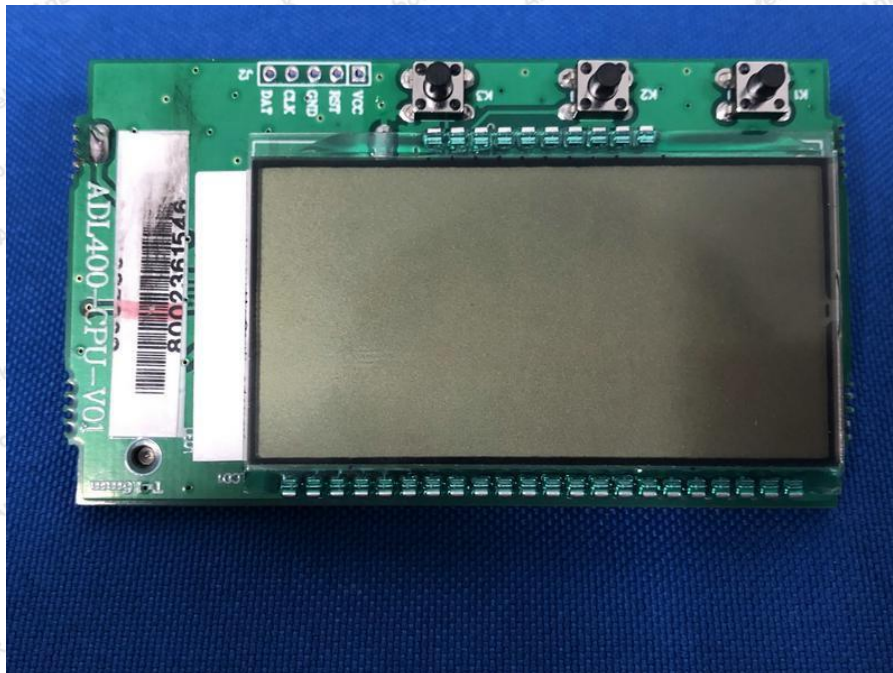
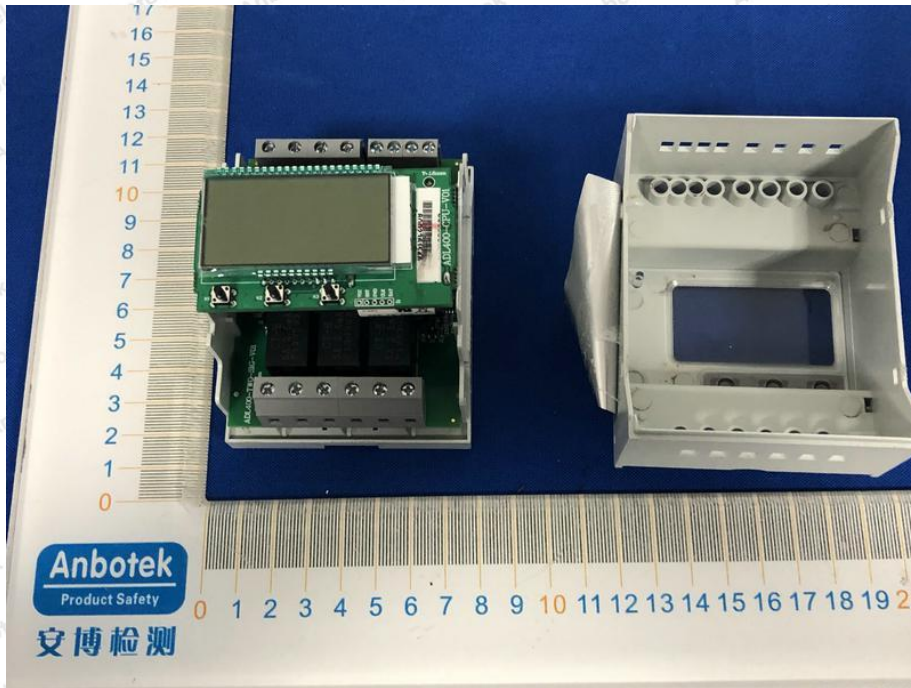
APPENDIX II -- EXTERNAL PHOTOGRAPH

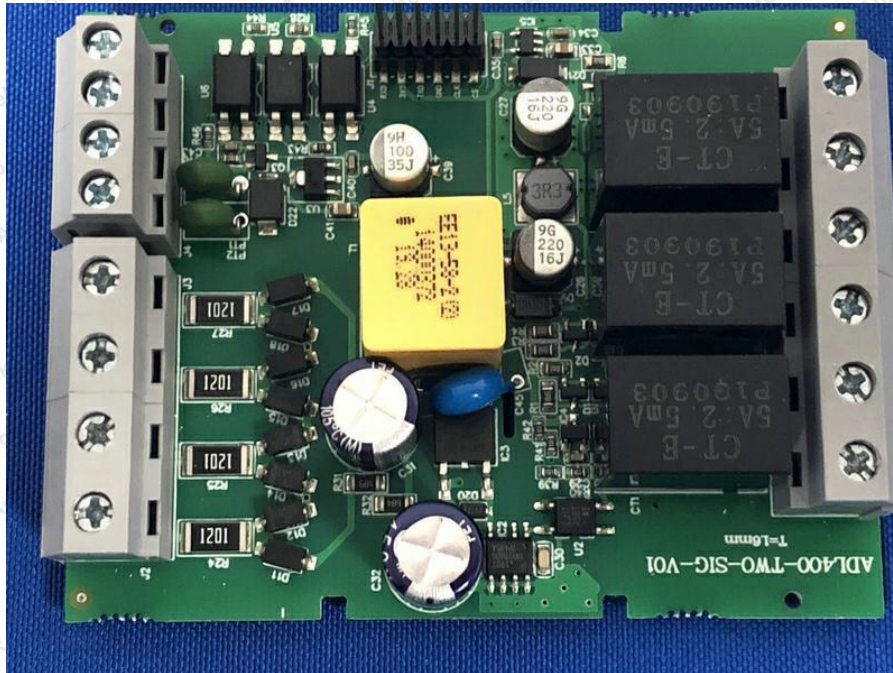
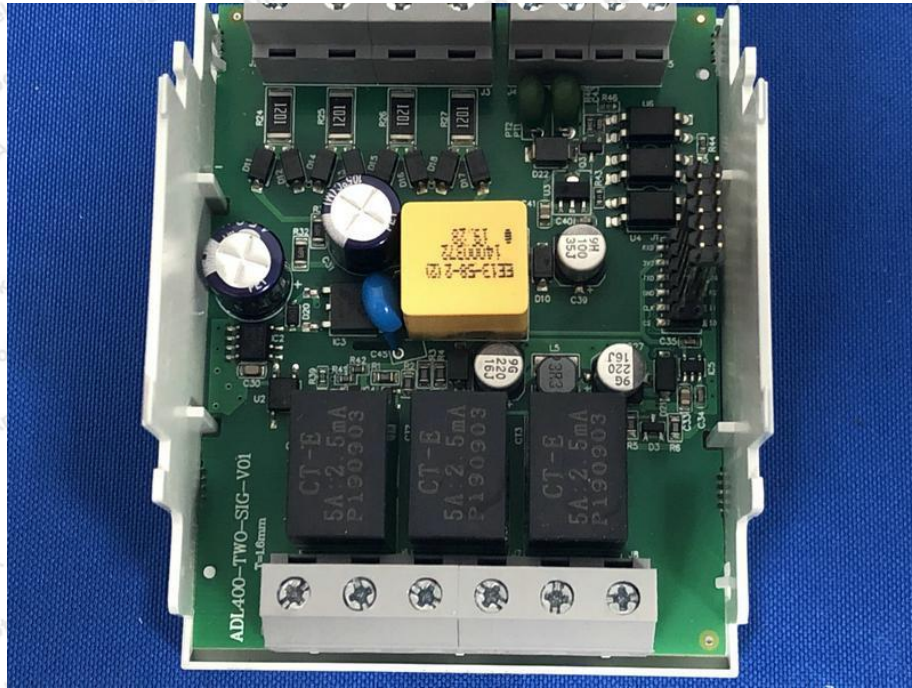




APPENDIX III -- INTERNAL PHOTOGRAPH







CE Label

1. The CE conformity marking must consist of the initials 'CE' taking the following form:

If the CE marking is reduced or enlarged, the proportions given in the above graduated drawing must be respected.

2. The CE marking must have a height of at least 5 mm except where this is not possible on account of the nature of the apparatus.

3. The CE marking must be affixed to the product or to its data plate. Additionally it must be affixed to the packaging, if any, and to the accompanying documents.

4. The CE marking must be affixed visibly, legibly and indelibly.

It must have the same height as the initials 'CE'.

----- End of Report -----

